

BE
SMART
TO
MARK

SM 5500

- Integrated Model
- Multiple Window Sizes
- 2d Datamatrix Code Marking

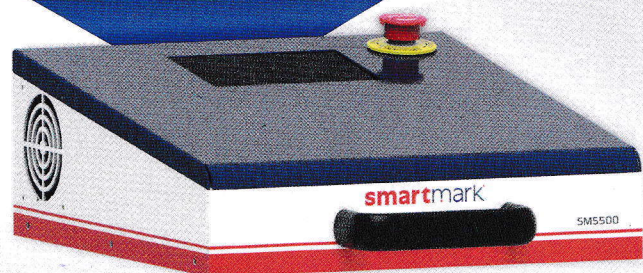

- Precision Dot Placement
- Fully Programmable Marking
- TCP/IP Connectivity

www.smartmarkingsolutions.com

Follow us –    

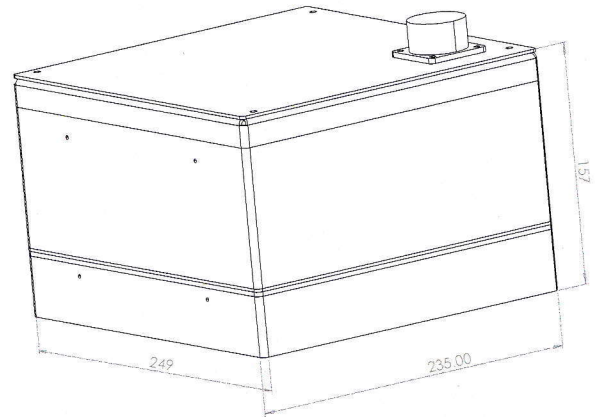
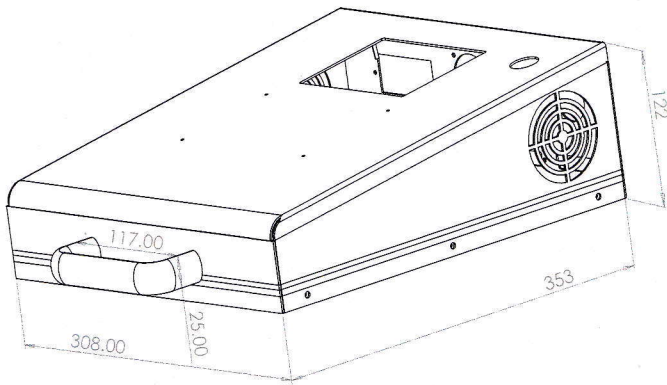

Technical Specifications

Weight- Marking Head = 12Kg, Controller= 10Kg

Electrical Supply: 240v 50Hz, 110v 60Hz

Marking Area: 100mmX100mm (Optional - 50mm X 50mm)

Memory Capacity: Up to 1350 inscription Layouts.

Stylus: 4mm x 70mm

Controller: Embedded LED Type

Keyboard: USB

X, Y Axis Control: Stepper motor driven

Start /Stop Box: Twin Button on manual

Marking Format: Dot matrix 5 x7, 7 x 9, Varidot, 2D Data Matrix code

America Europe India South east Asia

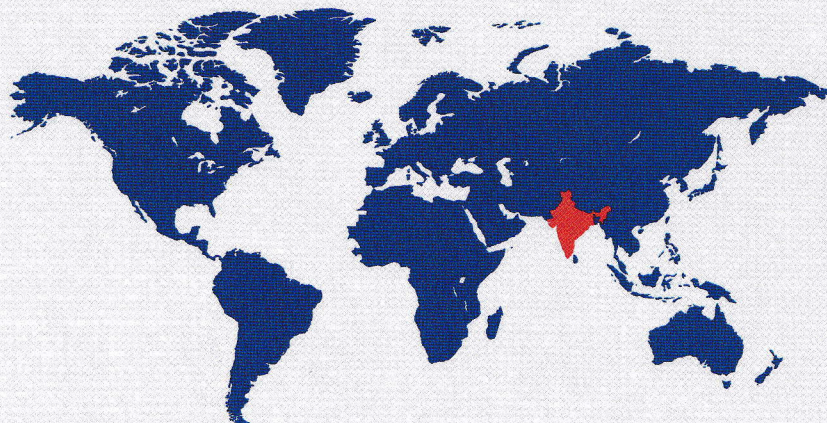

smartmark

www.smartmarkingsolutions.com

TOLL FREE 1800 209 5050

Mumbai, New Delhi, Kolkata, Chennai, Ahmedabad, Bangalore, Jamshedpur,
Ludhiana, Indore, Uttarakhand, Rajkot, Hyderabad, Coimbatore, Lucknow